



IST-2003-511670

# MOVEMENT

Modular Versatile Mobility Enhancement Technology

Specific Targeted Research or Innovation Project

IST

## Final publishable executive summary

Actual submission date: 15/02/2008

Start date of project: 01/09/2004

Duration: 40 months

Organisation name of lead contractor for this deliverable: TUW

Revision [final]

Project co-funded by the European Commission within the Sixth Framework Programme (2002-2006)		
Dissemination Level: RE		
PU	Public	
PP	Restricted to other programme participants (including the Commission Services)	
RE	Restricted to a group specified by the consortium (including the Commission Services)	
CO	Confidential, only for members of the consortium (including the Commission Services)	

Version: final

Version history

Version	Date	Changed	Author
final	15/02/2008	Compilation of material	PM/fortec

# Movement

The MOVEMENT project aimed at the development of a modular versatile mobility enhancement technology. The core is formed by an intelligent mobile (robotic) platform which can attach to a user definable selection of application modules (e.g. chair, manipulator, information and communication terminal) which are more or less inconspicuous mainstream articles but will become powerful assistive devices when the mobile platform attaches to them.

## Introduction

As mobility is a challenging key factor for personal independence and self determination and because it is inseparably linked to our quality of life, MOVEMENT stands for the transfer from the existing state of the art to a user oriented, modular as well as market compatible system approach to enhance societal mobility.

In our "Information Society", mobility can be described in three dimensions:

- MOVEMENT of PEOPLE: Transfer of persons to locations they want to access.
- MOVEMENT of OBJECTS: Transferring objects to facilitate an interaction with the person.
- MOVEMENT of INFORMATION: Access to and transport of information in the "Information Society".

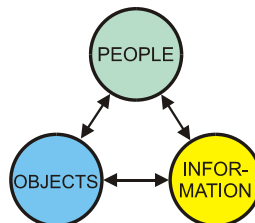

Fig.1: Interaction Triangle: Mobility in the "Information Society"

In a society where the percentage of old and disabled people is increasing at a significant rate, securing all three dimensions of mobility must be a social and technological goal of the highest priority. The MOVEMENT project will address all three dimensions of mobility in the "Information Society" by research into and development of realistic and practical modules for moving people, objects and information. Present state-of-the-art solutions such as conventional wheelchairs and stationary terminals or fixtures will be replaced by an expandable system of intelligent and interacting modules, which supports the personal mobility of old and disabled people.

## Motivation

Due to the continuously increasing life expectancy of people in western countries, the percentage of motor impaired people is constantly increasing. Less recent Europe-wide statistics denoted that 1% of the population is in need of a wheelchair and an additional 5.6% of people need some kind of walking aid. When also taking persons with chronic and age related diseases (poly-arthritis, rheumatism etc.) into account, recent statistics show much higher figures. In March 2003, the German Statistics Office calculated that 1.56 Million German citizens (1.9 % of the population) depended permanently or temporarily on a wheelchair. For Europe as a whole this translates to 7.1 Million people. The increasing

wheelchair usage due to ageing is shown in Fig. 2 (left). Analyses in the USA have shown that only 50% to 60% of people in need of a power wheelchair are in fact able to use state-of-the-art equipment. An additional 20% to 25% could be accommodated if more intelligent controls and user interfaces were available (Fig. 2, right).

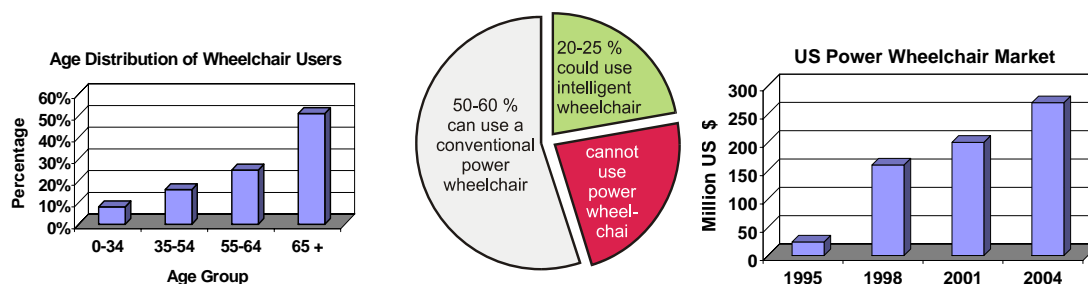

Fig. 2: Distribution of wheelchair users to age groups (left); usability of conventional wheelchairs and market segment for intelligent wheelchairs (right);

Loss of motor abilities (manipulation and locomotion) especially affects the aged female population not only due to their higher life expectancy, but also as a result of gender-specific chronic diseases. Whereas 31% of the male population aged 75-84 report mobility problems, the figure for the female population is as high as 52%. As the decrease in motor ability is gradual and slow, there is no pressing reason to begin using a wheelchair. Thus, the major part of the ageing population is shying away from using conventional mobility aids (crutches, walkers, wheelchairs) due to their stigmatising effects, even if walking causes increasing stress, fatigue and pain and despite the risk of falling and the consequences thereof.

## Project Aims

The last decade saw the evolution of more and more complex wheelchairs demonstrating capabilities for navigation, manipulation and transport. However, these systems never made it to commercialisation, since they are bulky and difficult to operate. They need to be engineered for each individual human and are still all in all very costly.

Recognizing the drawbacks, MOVEMENT aims at developing a new solution for supporting personal mobility which meets the users' expectations for an inconspicuous, non-stigmatising, tailor-able, ready to use and affordable mobility aid. As a consequence, the objectives of the project are:

- ◆ Addressing all three aspects of mobility (moving people, objects and information) by a fully modular set of assistive devices that can be freely assembled depending on the user's needs.
- ◆ Providing a concrete solution which can be placed on the assistive technology market soon after completion of the project.
- ◆ Pursuing an active dissemination and demonstration strategy by which users, care-givers and the health system is informed about the product under development, leading to awareness creation on a European level.

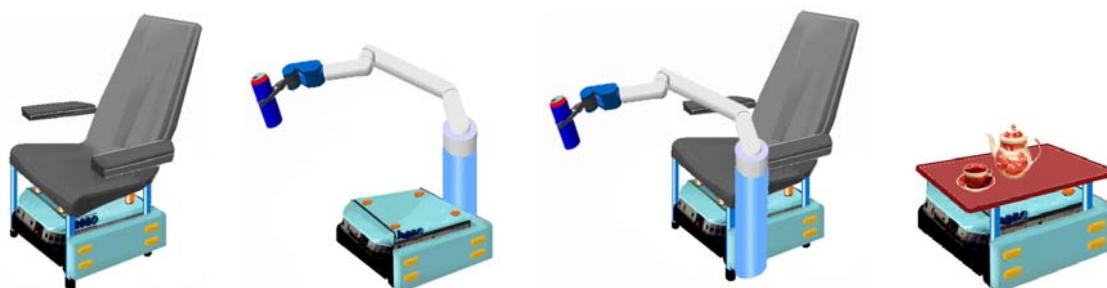

Fig. 3: Combinations of MOVEMENT-modules for moving people and moving and manipulating objects (concept).

To achieve these goals the consortium integrated research and commercial know how from recent developments in the required fields of industrial automation, transport and wheelchair technology, manipulation and robotics devices, perception and control engineering, human computer interface technology, assistive technology and gerontechnology.

## Work Progress

The project started with a specification for the interaction of the modules that were already defined very specifically in the project's work plan and the modelling of scenarios of use for the indoor environment, a restriction necessary because of the need to concentrate on a predictable and reproducible test setup first, that, nevertheless, offers challenging obstacle detection tasks (e.g. tables and other furniture).

User panels in Austria, Italy and the Netherlands were formed, taking into consideration users with mild, moderate and severe mobility restrictions from both the disabled and older age group. The developed concepts were presented to them and they were asked to give ratings to the different parts of the concept and their application.

The results of the user panels confirmed the overall concept of a modular system and provided important hints for the direction of development and the specification of the interaction of the system components.

After this approval of the project idea and its specification the core of the MOVEMENT system, the concept for the mobile platform was defined first. Taking into consideration the numerous requirements regarding payload, safety, automatic docking etc. a platform concept was developed based on existing know-how on autonomous robotic platforms.

In parallel, investigations on suitable sensor systems were carried out and the results were documented in a deliverable. First work on an appropriate development and evaluation environment for the MOVEMENT sensor system is done. Furthermore, concepts for sensor data fusion and data structures for storage and post-processing are under development.

Further work led to the elaboration of deliverables containing the concept for the different modules to be developed and the interfaces between them. By defining an XML-based wireless protocol a separate deliverable prepared the field for the communication channels that later on will be used to exchange status and command messages within the system.

In a similar way like the moving platform itself the docking mechanism between this platform and the application modules plays a central role in the project. Therefore a specific deliverable was prepared describing the mechanical and electrical properties of this important connecting part without which the modular concept could not be realized.

A first prototype of the mobile platform compliant to the MOVEMENT specifications but financed outside MOVEMENT was built and tested. Before the production of the first prototype the specifications of the mobile platform were enhanced and more precisely defined regarding the mechanical properties, also the costs for the platform had to be reduced before the production was started in January 2006. At this time the evaluation of the results of another user involvement round conducted in late 2005 again confirmed the project concept.

In early 2006 also the development of the first application module prototypes, a transportable chair and a transportable information and control terminal, was started. In the first half of 2006 the concepts for shared control and the sensor system were evaluated in simulated environments.



Fig. 4: First prototypes of application modules (simple) Chair and ICT

In late summer 2006 the platform prototypes and the application module prototypes were completed and laboratory testing was started. This was followed by a first evaluation of the system to gather input for the next prototyping phase.



Fig. 5: First prototypes of platform docked to (simple) Chair and ICT

A basic setup of a MOVEMENT system (platform with container module) was presented at the Rehacare 2006 in Düsseldorf to raise public awareness.



Fig. 6: First presentation at Rehacare 2006

The user feedback to the demonstration of the first prototypes was very encouraging. In early 2007 an improved prototype of the system with enhanced functionality in form of a Multi-functional Chair and a Lifter-Walker module, new sensor system and updated User Interface was developed. In early summer 2007 the user panels were invited to assess the 2<sup>nd</sup> prototype systems. The users were very enthusiastic about the transfer of concepts into real working prototypes.





Fig. 7: Prototypes of Multi-functional Chair and of height adjustable Table

A setup of a MOVEMENT system with Platform, Chair and Table module was presented at the Rehacare 2007 in Düsseldorf showing the transport of users and objects.



Fig. 8: Prototypes (Chair, Platform, Table) shown in action at Rehacare 2007

A final MOVEMENT prototype generation now also implementing the shared control between user and system in assisted joystick driving mode (user intention estimation), new sensors and improved communication software was developed and used for the final demonstration and evaluation tests.

Again the user panels were invited to test the new prototype functionality, this time with automatic and also assisted driving modes in home like settings. The summarized results confirm the original project ideas and support expectations to enter the market as quickly as possible with a first tailored MOVEMENT product integrated from the building blocks developed in the MOVEMENT project.

## The MOVEMENT Results

The final MOVEMENT prototype systems open up new perspectives in several areas. They are only first exemplary implementations with a range of innovative features that easily allow building a new generation of assistive devices.

- Modularity

MOVEMENT differs from other intelligent wheelchair designs by its mobile platform that can autonomously dock to several modules and always is there when it is needed and returns to a parking position otherwise. The docking functionality has been developed with the needed accuracy in home environments and evaluated successfully. The system can easily be extended demand driven with 3<sup>rd</sup> party modules at any time.

- Autonomy

MOVEMENT performs operations autonomously if the user wants it. Intelligently moving modules and driving to pre-defined locations releases the user from every-day tasks in single person settings at home and is able to manage multi-person multi-module fleets in institutional settings.

- Sensors

MOVEMENT unlike other intelligent wheelchairs is based on new unobtrusive sensors that cover a wider range of sight without the use of ultrasound thus not disturbing pets. The small and easy to integrate sensors are well suited for building of many intelligent devices where the design is not completely defined by technical constraints thus resulting in assistive modules without the typical laboratory or clinical touch that integrate seamlessly into typical house environments.

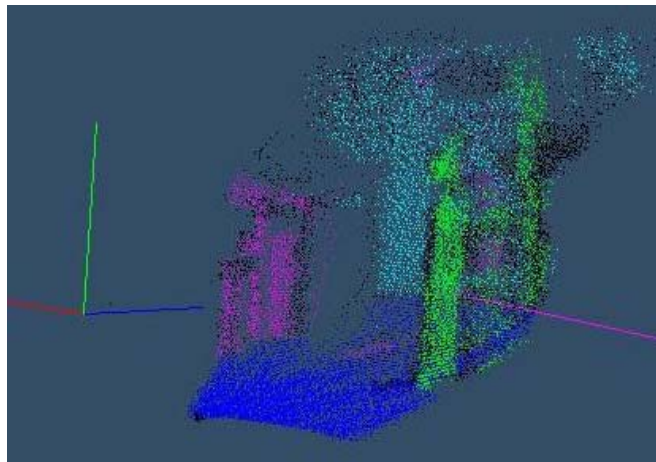

Fig. 9: Depth image from the sensor with automatically segmented objects

- Shared Control

MOVEMENT allows the user to decide how much assistance should be given by the system in manual driving mode. For this purpose a unique algorithm performs user intention estimation by analysis of the user's commands and overlay of an assistive signal to the user input.



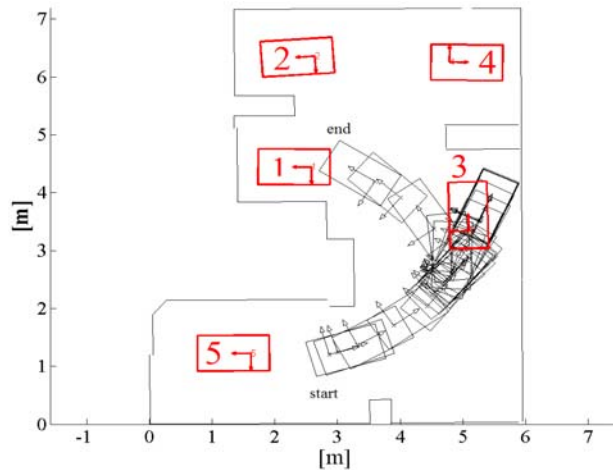

Fig. 10: Maneuver executed in a home-like environment. Possible intentions are displayed in red.

- Control and Communication

MOVEMENT integrates not only driving and movement but also communication and remote control functions into the system under a common flexible user interface. Remote control of home appliances, hands-free phone conversation, internet browsing and text-to-speech are built-in standard features. The cross-module and cross-platform communication has been established in a sophisticated way, well documented and is open for the integration of future modules.

- Flexible User Interface

MOVEMENT exposes a common user interface for all functions that allows individual design and configuration for every user. Command input selection and output format as well as presentation of status to the user are fully under control of a per user configuration changeable at runtime, offering multi-modal input and output individually tailored to the user needs even in multi-user scenarios.

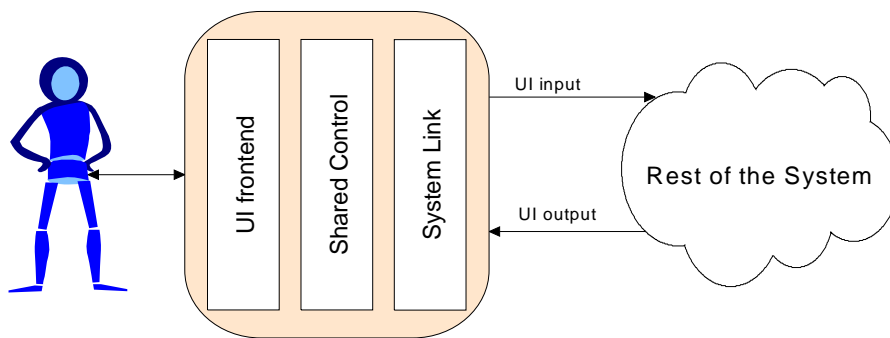

Fig. 11: Modular decomposition of the UI into sub-units

The flexible structure of the user interface permits the use of one common device to control all the various MOVEMENT system activities for all modules.

Besides a standard joystick and touchscreen various types of switch-type input devices including single switch scanning are supported out of the box. 3rd party devices with legacy interfaces as commonly used on PCs are either directly supported or by use of a driver layer and can be parameterised for the specific user.

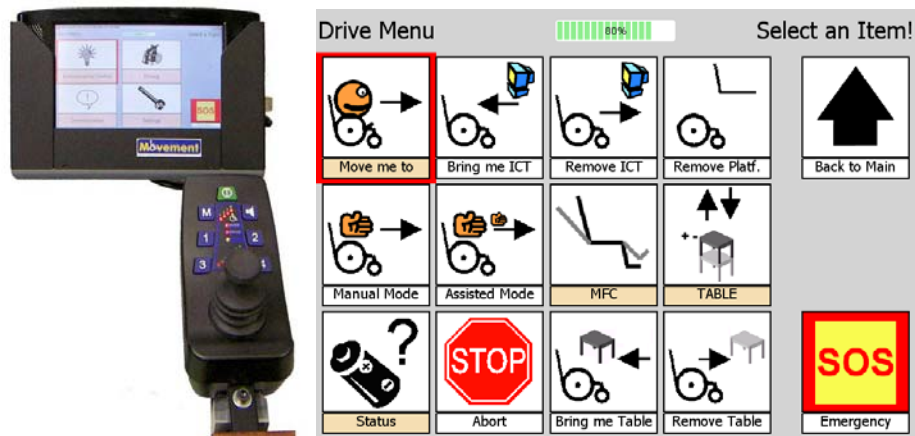

Fig. 12: User interface as seen from chair and exemplary menu for driving

The clear and big user interface was very positively commented during the evaluations by users and experts, though it was configured as a general demonstrator and only the individual adaptations will fully develop the usability for the specific end user.

### The MOVEMENT future

The next step after the project will be a field test implementation of a redesigned prototype for application in institutional settings to study the applicability for the prospective main market in real life over a longer period.

Many interesting combinations are expected to come up when the published 3rd party documentation is used by external parties to extend the prototype system to new application areas.

## The MOVEMENT consortium

### Austria

Vienna University of Technology, Automation and Control Institute and Institute “integrated study”;  
Austrian Research Centers GmbH - ARC, Business Units 'smart Biomedical systems'  
and 'Automation Systems';  
Profactor Research and Solutions GmbH

### Netherlands

Vilans/iRv Institute for Rehabilitation Research

### Switzerland

BlueBotics SA

### Germany

Otto Bock Health Care  
Technische Universität München , Lehrstuhl für Automatisierungstechnik

### Belgium

Katholieke Universiteit Leuven, Mobile Learning Robot research group

### Italy

Scuola Superiore Sant' Anna , Advanced Robotics Technology and Systems Laboratory

## MOVEMENT co-ordinator

Vienna University of Technology, Institute “integrated study”

Information: <http://www.is.tuwien.ac.at>

Contact: [mov-for@fortec.tuwien.ac.at](mailto:mov-for@fortec.tuwien.ac.at)

## MOVEMENT Homepage

<http://www.fortec.tuwien.ac.at/movement>

offers up-to-date information on the project status and download of public project deliverables and 3<sup>rd</sup>-party specifications.

*MOVEMENT is a Specific Targeted Research Project (contract number 511670) co-funded by the INFSO DG of the European Commission within the RTD activities of the Thematic Priority Information Society Technologies (Activity code IST-2002-2.3.2.10. of the 6th Framework Programme) during 2004-2007.*